

R254/90

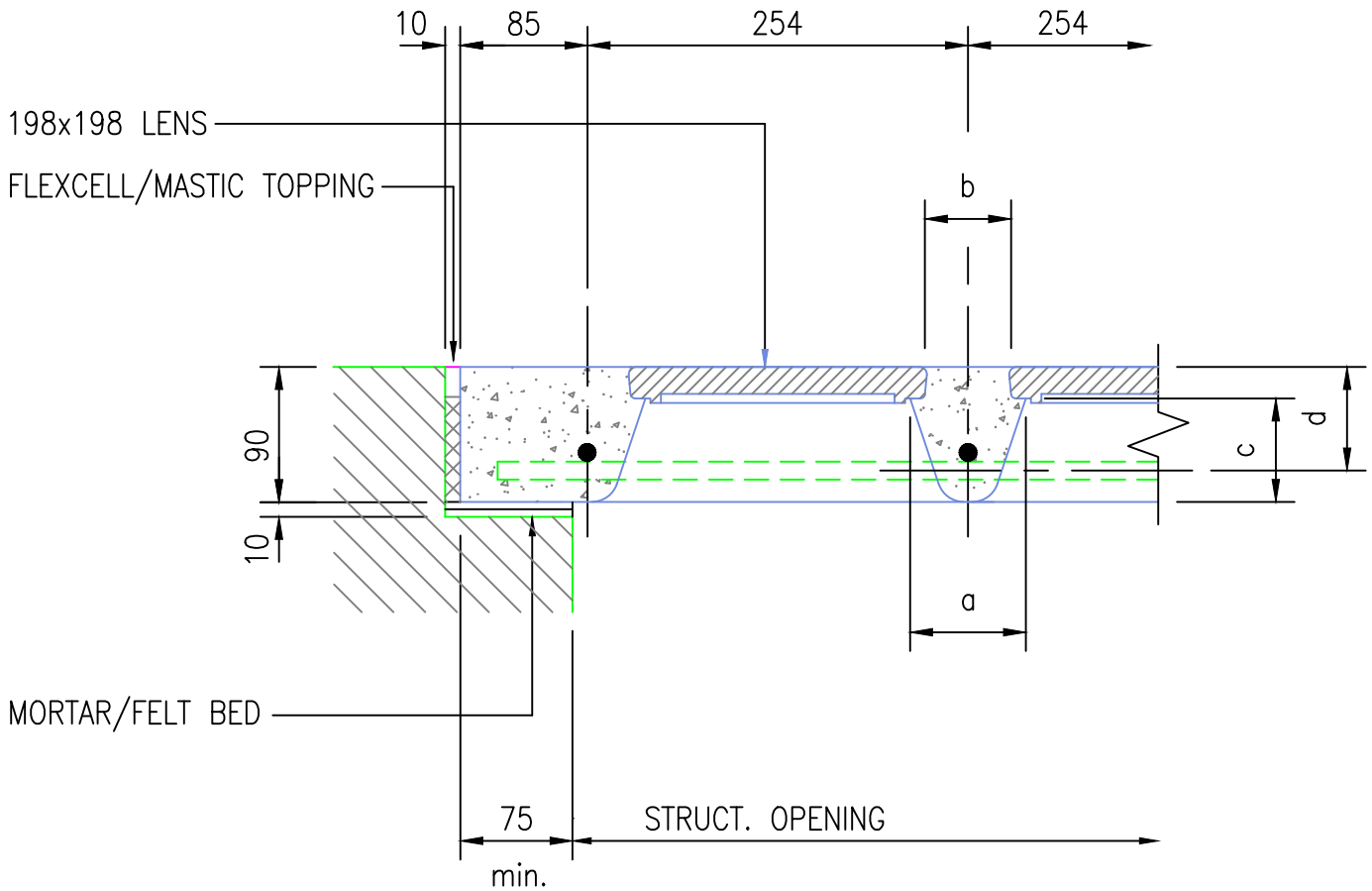

TYPICAL EDGE/CROSS SECTION

SUPERIMPOSED LOADING

1.5KN/m² – 1.850m Max. CLEAR SPAN

2.5KN/m² – 1.750m Max. CLEAR SPAN

5.0KN/m² – 1.500m Max. CLEAR SPAN

CONCENTRATED LOADING

75KN ULTIMATE – N/A

SELF WEIGHT = 150kgs/m²

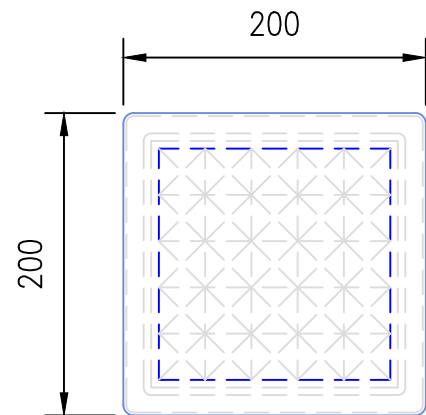

LENS PATTERN
(SCALE=1:5.)

FOR DIMENSIONS 'a', 'b', 'c' and 'd' PLEASE REFER TO THE RELEVANT DESIGN CRITERIA DETAIL SHEET Nos. PL-SPAN1 to 9 inc.

luxcrete

LIMITED

Unit 2 Firbank Industrial Estate
Dallow Road Luton
Bedfordshire
LU1 1TW

T:01582 488767
F:01582 724607
www.luxcrete.co.uk
E:enquiries@luxcrete.co.uk

LUXCRETE OPERATE A POLICY OF CONTINUAL IMPROVEMENT OF THEIR PRODUCTS. SPECIFICATIONS AND DETAILS ARE THEREFORE SUBJECT TO CHANGE WITHOUT NOTICE. ALL TECHNICAL INFORMATION CONTAINED WITHIN THIS DETAIL SHEET IS FOR GUIDANCE ONLY AND MAY BE INAPPROPRIATE UNDER PARTICULAR CONDITIONS.



2011 COPYRIGHT LUXCRETE LTD