

CONSTRUCTION DRG No.

## S150/115

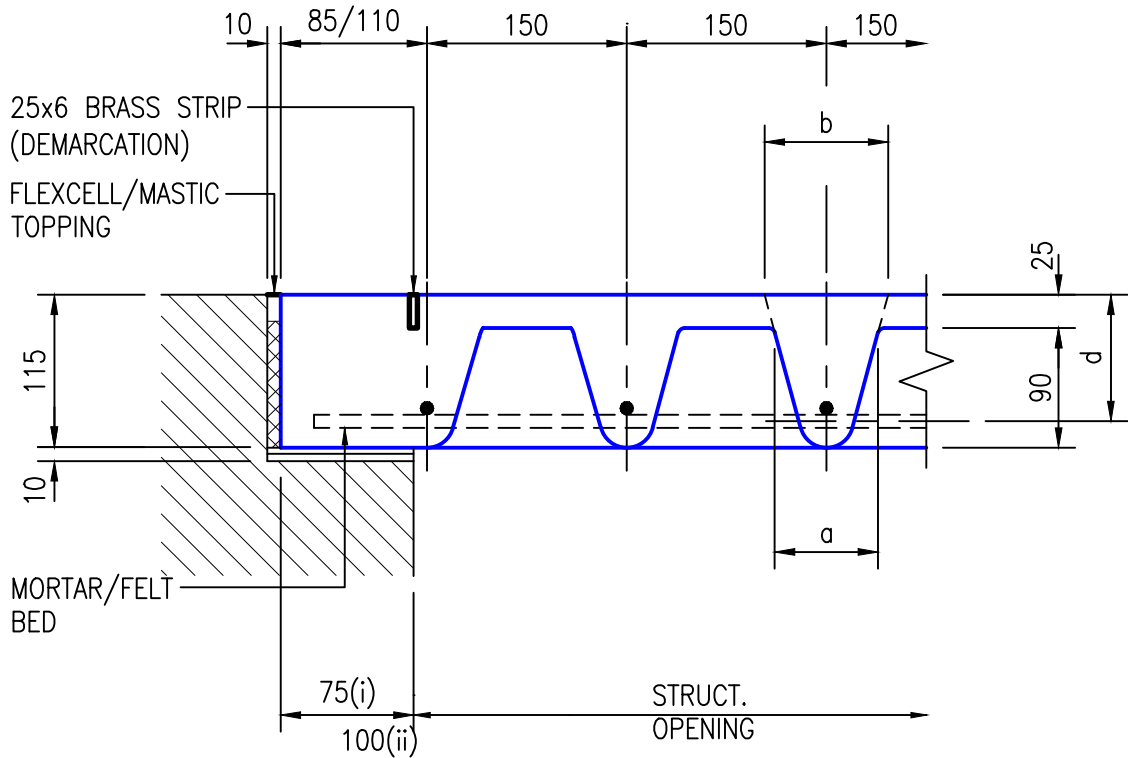

### TYPICAL EDGE/CROSS SECTION

#### SUPERIMPOSED LOADING

5KN/M<sup>2</sup> – 3.050M Max. CLEAR SPAN (i)

10KN/M<sup>2</sup> – 2.710M Max. CLEAR SPAN (i)

20KN/M<sup>2</sup> – 1.950M Max. CLEAR SPAN (i)

#### CONCENTRATED LOADING

75KN ULTIMATE – 1.500M Max. CLEAR SPAN (ii)

SELF WEIGHT = 190kgs/M<sup>2</sup>

FOR DIMENSIONS 'a', 'b', 'c' and 'd' PLEASE REFER TO THE RELEVANT DESIGN CRITERIA DETAIL SHEET Nos. PL-SPAN1 to 9 inc.

# luxcrete

LIMITED

Unit 2 Firbank Industrial Estate T:01582 488767  
Dallow Road Luton F:01582 724607  
Bedfordshire www.luxcrete.co.uk  
LU1 1TW E:enquiries@luxcrete.co.uk

LUXCRETE OPERATE A POLICY OF CONTINUAL IMPROVEMENT OF THEIR PRODUCTS. SPECIFICATIONS AND DETAILS ARE THEREFORE SUBJECT TO CHANGE WITHOUT NOTICE. ALL TECHNICAL INFORMATION CONTAINED WITHIN THIS DETAIL SHEET IS FOR GUIDANCE ONLY AND MAY BE INAPPROPRIATE UNDER PARTICULAR CONDITIONS.

© 2011 COPYRIGHT LUXCRETE LTD