

CONSTRUCTION DRG No.

CU/R165/75

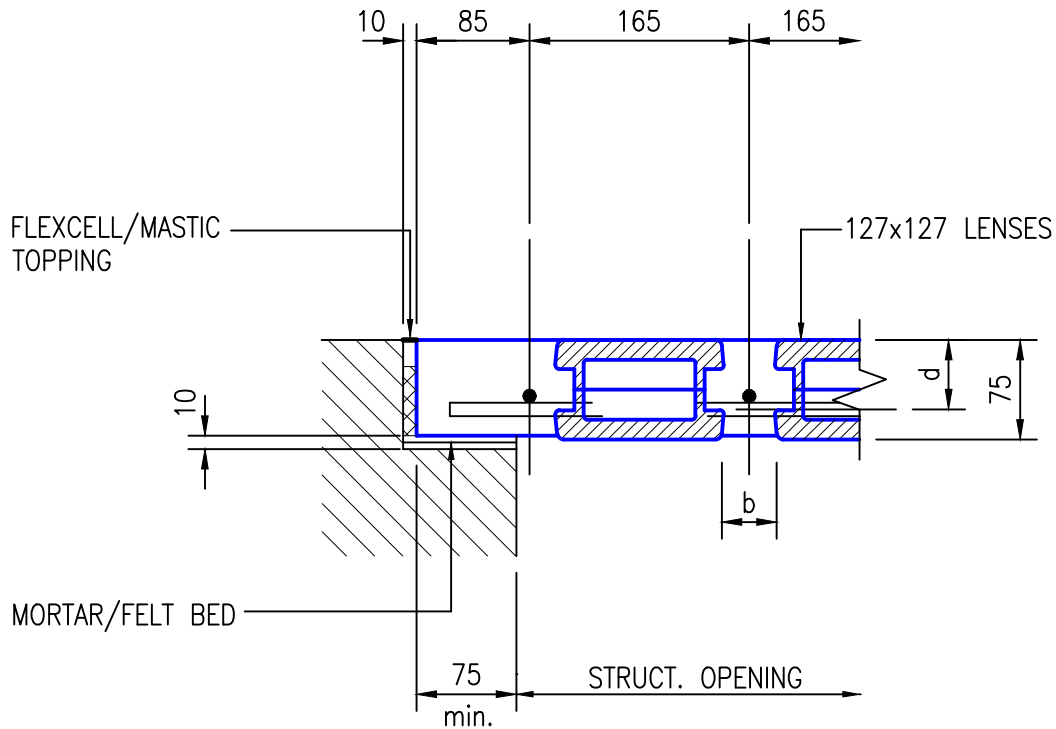

TYPICAL EDGE/CROSS SECTION

SUPERIMPOSED LOADING

1.5KN/M² – 2.055M Max. CLEAR SPAN
2.5KN/M² – 1.900M Max. CLEAR SPAN
5.0KN/M² – 1.470M Max. CLEAR SPAN
10.0KN/M² – 1.100M Max. CLEAR SPAN

CONCENTRATED LOADING

75KN ULTIMATE – N/A
SELF WEIGHT = 61kgs/M²

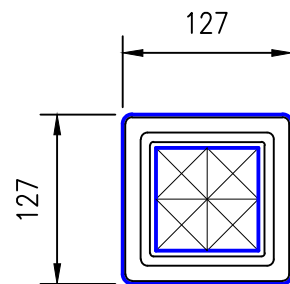

LENS PATTERN
(SCALE=1:5.)

FOR DIMENSIONS 'a', 'b', 'c' and 'd' PLEASE REFER TO THE RELEVANT DESIGN CRITERIA DETAIL SHEET Nos. PL-SPAN1 to 9 inc.

luxcrete

LIMITED

Unit 2 Firbank Industrial Estate T:01582 488767
Dallow Road Luton F:01582 724607
Bedfordshire www.luxcrete.co.uk
LU1 1TW E:enquiries@luxcrete.co.uk

LUXCRETE OPERATE A POLICY OF CONTINUAL IMPROVEMENT OF THEIR PRODUCTS. SPECIFICATIONS AND DETAILS ARE THEREFORE SUBJECT TO CHANGE WITHOUT NOTICE. ALL TECHNICAL INFORMATION CONTAINED WITHIN THIS DETAIL SHEET IS FOR GUIDANCE ONLY AND MAY BE INAPPROPRIATE UNDER PARTICULAR CONDITIONS.

© 2011 COPYRIGHT LUXCRETE LTD